

FRONT VIEW

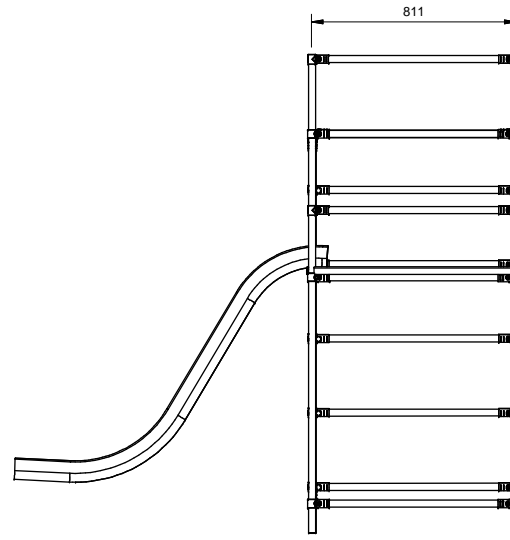

SIDE VIEW

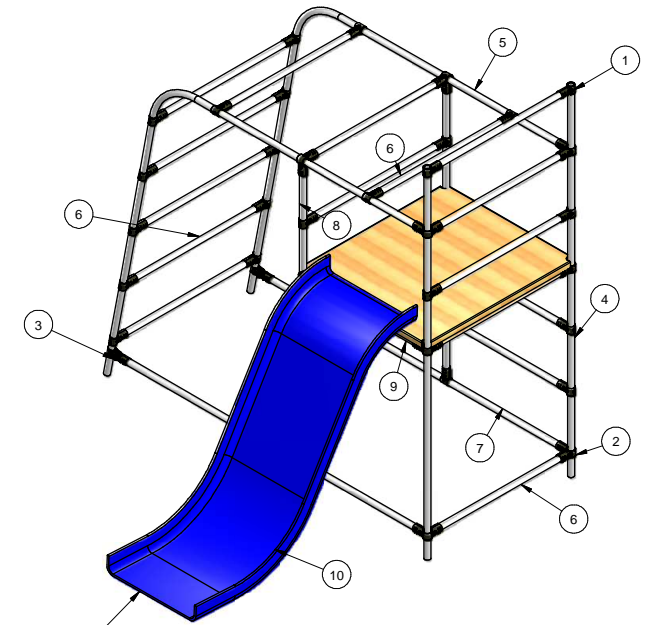

CLIENT CAN SOURCE SLIDE DIRECTLY FROM SUPPLIER



TOP VIEW

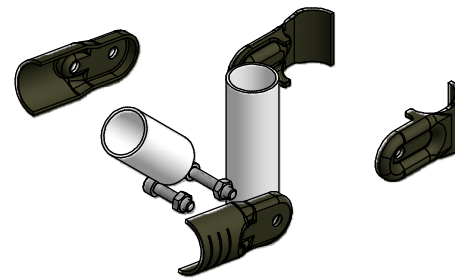

G7 CONNECTION

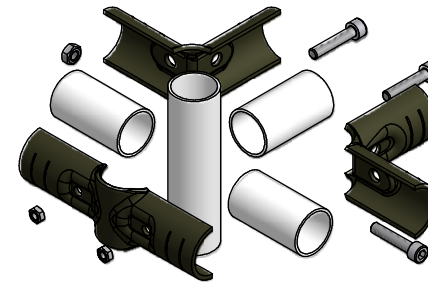

G3 CONNECTION

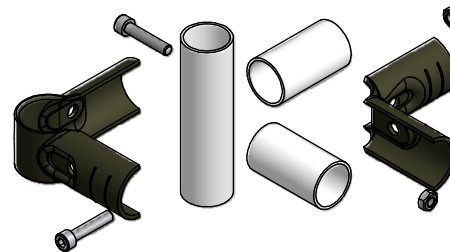

G2 CONNECTION

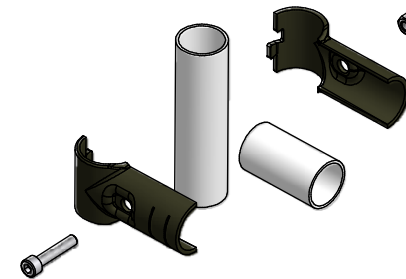

G1 CONNECTION

Parts List			
ITEM	QTY	PART NUMBER	LENGTH
1	26	G1 CONNECTION	
2	10	G2 CONNECTION	
3	2	G7 CONNECTION	
4	2	JGB-PIPE - 1	1900,0 mm
5	2	JGB-PIPE - 2	3000,0 mm
6	15	JGB-PIPE - 3	730,0 mm
7	2	JGB-PIPE - 4	1650,0 mm
8	2	JGB-PIPE - 6	1400,0 mm
9	4	JGB-PIPE - 5	650,0 mm
10	1	SLIDE	
31	1	PLATFORM	

IF IN DOUBT ASK
 ALL DIMENSIONS ARE IN MILLIMETRES
 DRAWING TO SABS 0111
 TOLERANCES TO SABS ISO 286, UNLESS OTHERWISE STATED.
 WELDING SYMBOLS TO SABS ISO 2553
 REMOVE ALL BURRS AND SHARP EDGES.

ALL SURFACES TO BE MACHINED UNLESS OTHERWISE SPECIFIED (Ra) 1.6
 MACH. TOL. X = ±0.5, X.X = ±0.2, X.XX = ±0.1, ALL FLAME CUTS = ±1.5
 EDGE FINISH \sqrt{Ra} +0.4, \sqrt{Ra} -0.4

DO NOT USE FOR MANUFACTURE OR INSPECTION UNLESS STAMPED WITH THE RELEASED FOR MANUFACTURE STAMP. ALWAYS REFER TO THE LATEST REVISION.

MANUF:	DES:	DATE:	REV:	DATE:	BY:
				2008/08/11	

CUSTOMER: EZI RACKING PROJECT: CATALOGUE DRAWINGS

TITLE: JUNGLE GYM B
 DRAWING NUMBER: JUNGLE GYM B

		SCALE: NTS
		SIZE: ISO A3
		SHEET: REV 1/1